

BLACK-OPS™
AUTO GLASS REMOVAL TOOL

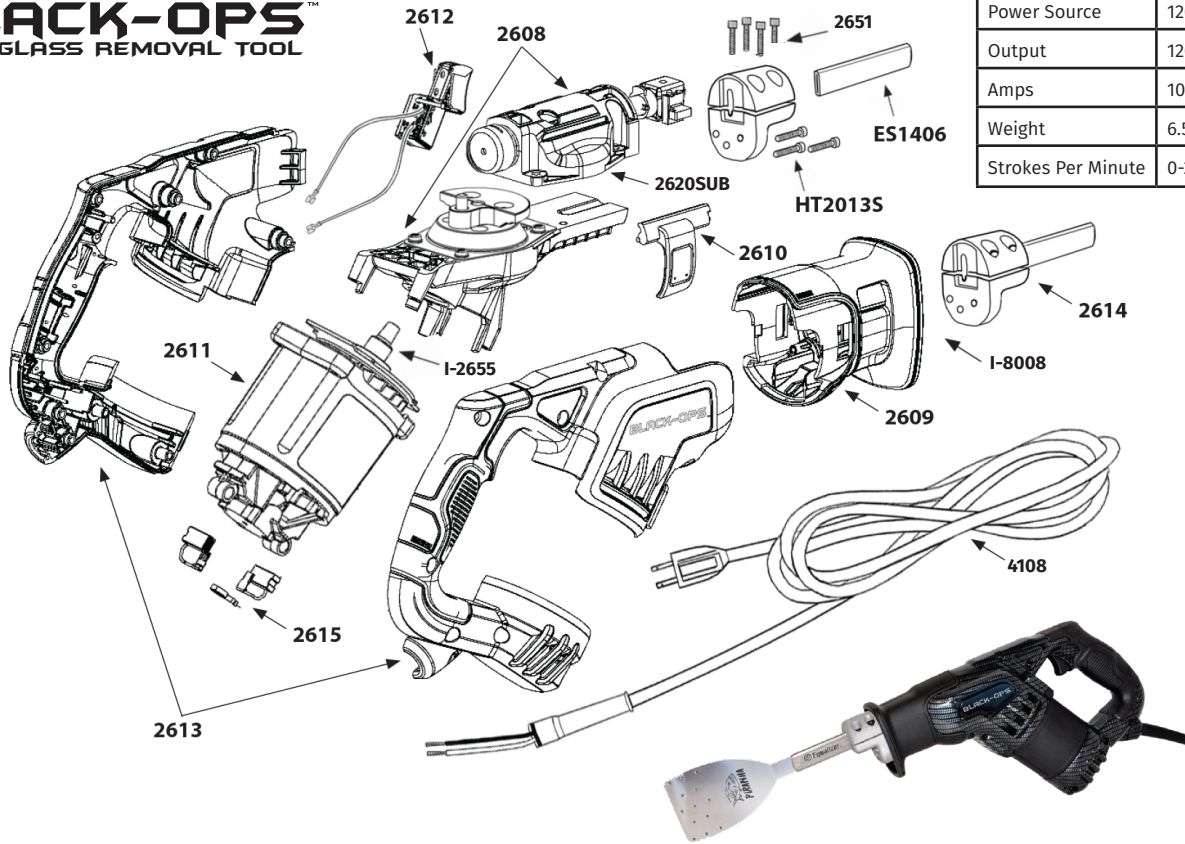

HHT2013 Specifications

Power Source	120 Volts
Output	1200 Watts
Amps	10 Amp
Weight	6.5 lbs
Strokes Per Minute	0-2,800

Part No.	Description of part	Qty
2651	Sheath Clamp Screws (Set of 4)	1 set
HT2013S	Base Mounting Screws (Set of 3)	1 set
2608	Gear Case includes all internal parts and gear case plate	1
2620SUB	Sub Assembly	1
2609	Gear Case Cover Boot	1
2610	Blade Release	1
2611	Drive Motor Assembly (includes drive motor cover)	1
I-2655	Armature & Bearings	1
2612	Switch With Lead Wires	1
2613	Replacement Handle Set	1 set
2614	Complete Sheath Clamp Assembly (includes: 1 sheath clamp, 1 set of 2651 screws, 1 set HT2013S screws and 1 ES1406 sheath)	1
I-8008	Spacer	1
2615	Brush Set	1 set
4108	Power Cord With Protective Cover	1
ES1406	Equalizer® Express® Sheath	1

NEED TO REQUEST AN RMA FOR A REPAIR?

